

Name :- TestUser  
Vehicle No :- TEST1(4758)

Company Name :- Testing  
Company Shift:- Morning(21:35 to 07:35)



**WITH ENGINE is OFF CHECK THE FOLLOWING**

		Select No For Damage/Others	Remark
1	Kilometer at start of shift	125	tack over 247
2	ENGINE LIGHTS INDICATOR WARNING	NO	not working indicator warning
3	EXTERIOR OF VEHICLE CLEAN	NO	
4	INTERIOR OF VEHICLE CLEAN	NO	
5	WINDSHIELD WIPERS	YES	
6	SEAT BELT FUNCTIONS CORRECTLY	NO	not working
7	TIRE TREAD AND SIDEWALLS SHOW NO DAMAGE	YES	



**TURN ON THE ENGINE CHECK THE FOLLOWING**

		Select No For Damage/Others	Remark
1	HEADLIGHTS FUNCTION ON BOTH HI AND LO BEAM	NO	headlight is deam
2	TURN SIGNALS FUNCTION (Left/Right)	YES	
3	BRAKE LIGHTS FUNCTION INCLUDING THIRD BRAKE LIGHT	YES	
4	FLUID LEAKS DISCOVERED	NO	not overed
5	HORN SOUNDS	YES	
6	MIRRORS FUNCTION AND ARE CLEAN	YES	
7	EMERGENCY LIGHTS AND SIREN WORK	NO	not work
8	FLUID LIGHTS WORKING	YES	
9	BEACON LIGHTS WORKING	YES	
10	Vehicle Pass Valid	YES	
11	Specify Vehicle Fuel	YES	
12	Vehicle Equipment	YES	
13	ANY NEW DAMAGE NOTED PRIOR TO USING THIS VEHICLE?	YES	

**Others**

		Select No For Damage/Others	Remark
1	Specify the Tetra Number (1)	8	testing
2	Specify the Tetra Number (2)	8	tetra number testing
3	Specify the iPad number	N/A	
4	Specify the Tab Number	N/A	

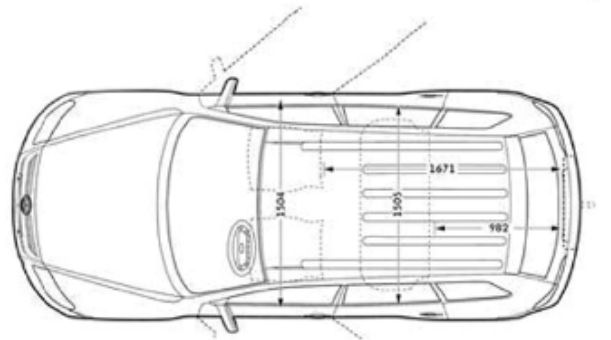
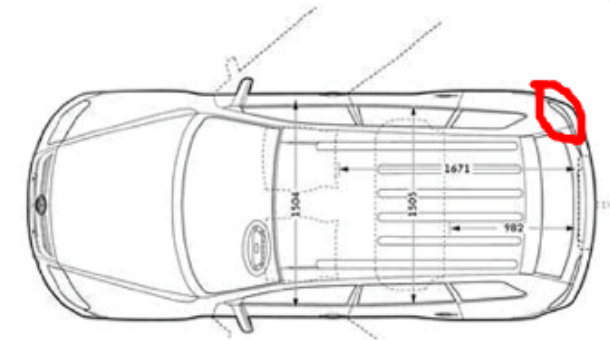
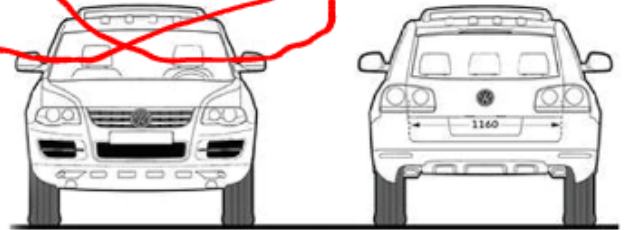
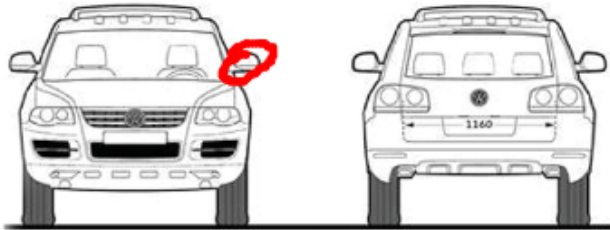
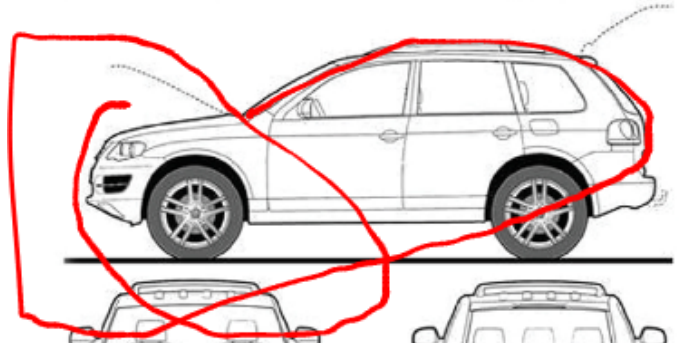
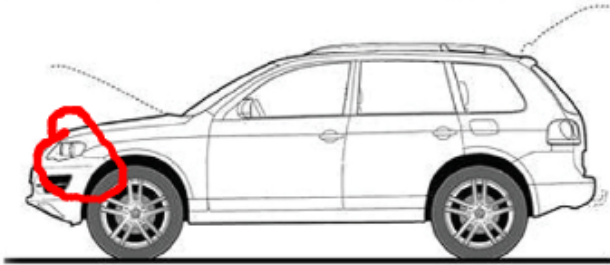
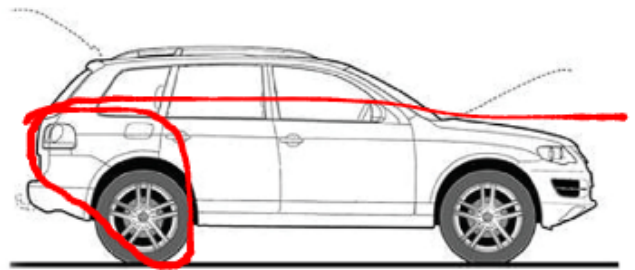
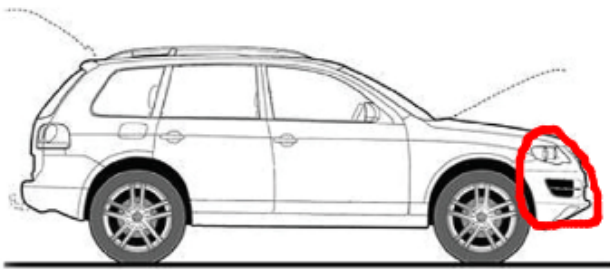

**User Remark:**

Testing